



# The MICROCALVET line

*FOR SUPERIOR SENSITIVITY*



## MICROCALORIMETRY & APPLICATIONS

**KEP Technologies is not simply an instrument company, but a full solution provider.**

We do not claim that a single product is suited for all applications and have with our SETARAM brand developed a range of products with different characteristics to more closely meet your demands.

We are confident that with KEP Technologies you will find a dedicated microcalorimetry solution with the performance you need to get the best understanding of your materials. This being the case no matter which of our below market segments you may work in.



### ENERGY & ENVIRONMENT

Gas hydrates formation and dissociation, wax appearance temperature, up to high pressure.  
Characterization of heat storage materials, of heat transfer fluids  
Heat of sorption for the characterization of catalysts, sorbents, CO2 capture and sequestration processes.



### LIFE SCIENCES

Thermal stability of biomolecules and biosystems, proteins, enzymes, antibodies, vesicles, liposomes, membranes & micelles  
Polymorphism / Crystallinity of solid drugs  
Thermal behavior of food, and of food components like lipids, carbohydrates, proteins. It includes melting, crystallization, powder dissolution, gel formation etc.  
Metabolism of living organisms like bacteria or yeast



### ORGANIC MATERIALS SCIENCE

Polymers and plastics thermal and thermophysical properties, impact of high pressure process conditions.  
Transitions of polymers in solution.



### PROCESS SAFETY

Long term thermal stability of energetic materials



### INORGANIC MATERIALS SCIENCE

Thermophysical properties of ceramics, glass, metals and alloys, cements. Setting and hydration properties of cements.

## THE KEP TECHNOLOGIES ADVANTAGE

Each MICROCALVET microcalorimeter also embodies our "Reimagine Material Characterization" value proposition. It does so by delivering the three core customer benefits of Experimental Control, Instrument Versatility and Quality Results.

We know that solutions that provide these benefits will deliver the highest value to our customers.

In addition to our core customer benefits, we are able to provide customized solutions by harnessing the engineering and project management expertise of our highly skilled organization.

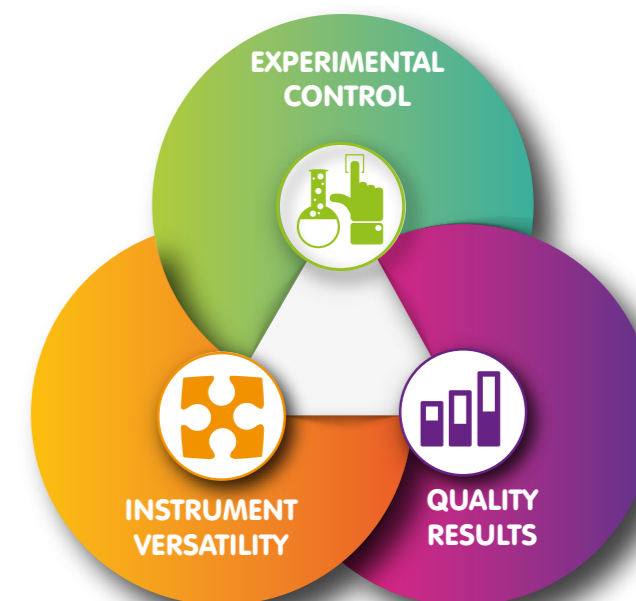

### CUSTOMIZED SOLUTIONS

Modular design allows for upgraded and tailored functionality  
Access to all previous non-proprietary custom requests  
Open access to engineering development team

## THE MICROCALVET LINE

Owing to their 3D sensors and Joule effect calibration, the MICROCALVET line of microcalorimeters combine the highest sensitivity and the most accurate measurements of temperature and of:

- Heat: for the characterization of any heat releasing or heat absorbing phenomenon
- Specific Heat Capacity ( $C_p$ ): for any application requiring this key thermophysical property, like heat transfer calculation or heat management

The microcalorimeters of the MICROCALVET line use the latest evolution of the 3D sensor design in which a sample and reference cells are surrounded by semiconductor-based Peltier elements allowing for the measurement of all heat including radiation, convection or conduction. The 3D sensor is up to 95% efficient whereas typical plate DSC sensors are between 30-50%.

MICROCALVET line sensors use a specific electrical calibration also called Joule effect. It can be performed at any constant temperature, or under scanning conditions, and does not require reference materials.

The combination of 3D sensor efficiency and absolute Joule effect calibration provides an unparalleled accuracy of measurement independent of sample nature or matrix – solid, liquid, gas, powder etc.

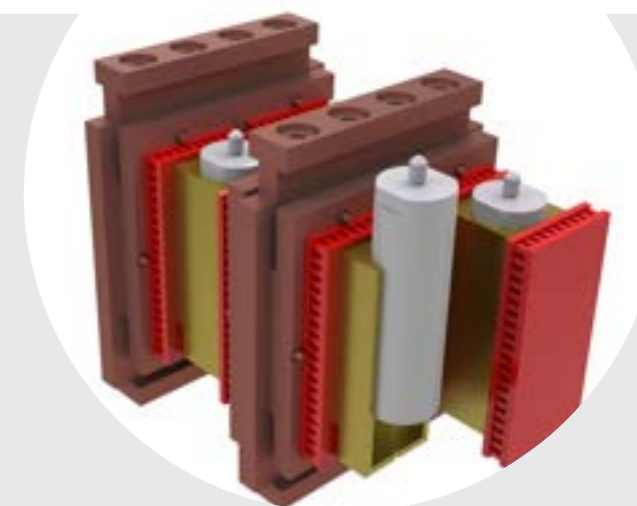

# MICROCALVET LINE CALORIMETERS

Our range of microcalorimeters for the characterization of materials across wide temperature ranges and using all common calorimetry techniques.

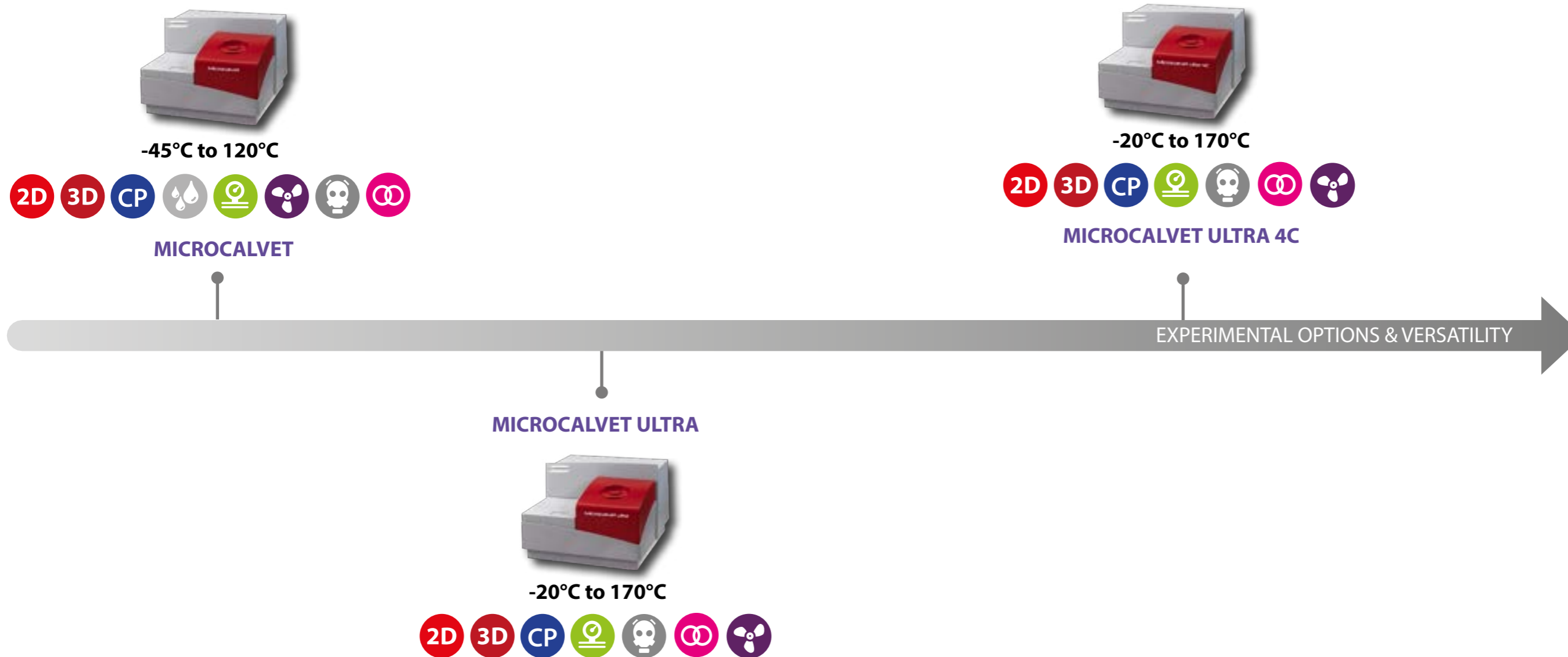

## PLUG-IN ACCESSORIES

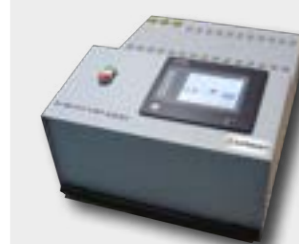

**FLEXI HP**  
High Pressure

Measurement and control of sample pressure



**FLEXI WET**  
Humidity Control

Stand alone wet gas generator

## CALISTO - CALORIMETRY SOFTWARE

CALISTO 2.0 is the industry standard calorimeter software developed for all Setaram instrumentation and applications. It's quick to install and comprises of two independent parts:

- **CALISTO ACQUISITION:** dedicated to the control and data acquisition of our calorimetry systems.
- **CALISTO PROCESSING:** for the treatment of calorimetry data independent of instrument type.

CALISTO software includes over 100 customer-requested features and promises to be the most powerful, flexible and intuitive data treatment software in calorimetry.

See [calisto-software.com](http://calisto-software.com) for more information on the power of Calisto 2.0 software.

### 2D DSC - DIFFERENTIAL SCANNING CALORIMETRY

Measures heatflow, heat and heat capacity

### MIXING

Can mix two or more samples inside the calorimeter sensor for heat of mixing measurements

### HUMIDITY

Can be coupled with FLEXI WET or other relative humidity accessories

### 3D 3D CALVET SENSOR

Three dimensional measurement capturing up to 95% of heat for unparalleled accuracy and precision

### CORROSIVE AND REACTIVE GASES

Able to run in various aggressive atmospheres according to the calorimeter's configuration

### PRESSURE VACUUM

Operates under high pressure and vacuum

### CP HEAT CAPACITY

Ideal tool for accurate heat capacity measurements

### COUPLING

Couples with GASPRO option

# MICROCALVET



- HIGHEST HEAT MEASUREMENT ACCURACY**  
 Calvet 3D sensor based on Peltier elements with Joule effect calibration
- MODIFIABLE TEMPERATURE CONDITIONS**  
 for increased flexibility and replication of real life conditions between -45 and 120°C
- CONVENIENT INTERCHANGEABLE CRUCIBLES AND CELLS**  
 to perform even the most demanding experiments using one instrument :
  - high pressure (up to 1000 bar) and high vacuum, pressure measurement and control
  - mixing/stirring experiments
  - combined high pressure and stirring experiments
- EXTERNAL COUPLING CAPABILITY**  
 designed to increase your research options including manometry, BET instrumentation, gas analyzers, humidity controllers and gas panels

TEMPERATURE	MICROCALVET
<b>Temperature range (°C)</b>	-45 to 120 <i>Cooling under 0 °C requires the use of an auxiliary thermostat</i>
<b>Temperature accuracy (°C)</b>	+/- 0.07*
<b>Temperature precision (°C)</b>	+/- 0.15*
<b>Programmable temperature scanning rate (°C/min)</b>	0.001 to 2
HEAT & HEAT FLOW	
<b>Enthalpy accuracy (%)</b>	+/- 0.4*
<b>Calorimetric precision (%)</b>	+/- 0.7*
<b>RMS noise (µW)</b>	0.08
<b>Resolution (µW)</b>	0.002; 0.02
<b>Dynamic Range (mW)</b>	+/- 12; +/- 120
GENERAL	
<b>Cells volume (ml)</b>	Up to 1 (standard cell)
<b>Pressure measured and controlled (bar [psi])</b>	400 [5,800]; 1000 [14,600]
<b>Weight (kg)</b>	38
<b>Dimensions (Height/Width/Depth)</b>	40/53/58 cm 15.7/20.9/22.8 inch
<b>Power requirements</b>	230V-50/60 Hz

\* Based on naphthalene melting tests

MICROCALVET's solid-state thermostat is composed of two concentric temperature control chambers which accurately set the temperature of the 3D sensor and cells. This robust design enables the fine-tuning of the heating and cooling rates even down to 0.001°C/min and the very good temperature stability of MICROCALVET.

The 3D sensor of MICROCALVET is composed of highly sensitive Peltier elements. They have one face in contact with the measurement cell and another in contact with a solid-state thermostat.

The sample, within a measurement cell, is placed directly into the center of the sensor's measurement zone. The cell can be a simply closed cylinder, or equipped with tools for mixing and stirring, gas or liquid flow, pressure control, and coupling to extra instrumentation.

Cells and tools are made of temperature and corrosion resistant metals and polymers.

New cells can be designed and configured to suit your application.

A water circuit controls the external temperature of the solid state thermostat to preserve it's Peltier elements. At the minimum (-45°C) and maximum (120°C) temperatures of MICROCALVET, the external temperature of the thermostat can be very high or very low, respectively.

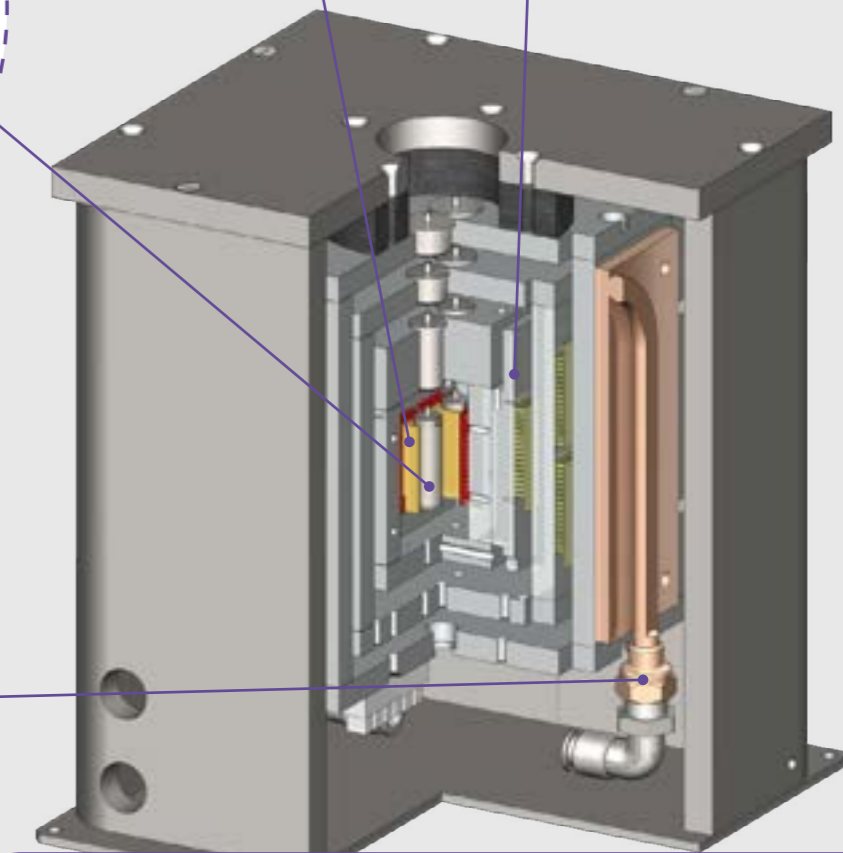

Cross section of the MICROCALVET calorimeter

## MICROCALVET ULTRA



- HIGHEST HEAT MEASUREMENT ACCURACY**  
 Calvet 3D sensor based on Peltier elements with Joule effect calibration
- MODIFIABLE TEMPERATURE CONDITIONS**  
 for increased flexibility and replication of real life conditions between -20 and 170°C
- CONVENIENT INTERCHANGEABLE CRUCIBLES AND CELLS**  
 to perform even the most demanding experiments using one instrument :
  - high pressure (up to 400 bar) and high vacuum, pressure measurement and control
  - mixing experiment
- EXTERNAL COUPLING CAPABILITY**  
 designed to increase your research options including manometry, BET instrumentation, gas analyzers, humidity controllers and gas panels

TEMPERATURE	MICROCALVET ULTRA
Temperature range (°C)	-20 to 170
Temperature accuracy (°C)	+/- 0.07*
Temperature precision (°C)	+/- 0.15*
Programmable temperature scanning rate (°C/min)	0.001 to 1.2
HEAT & HEAT FLOW	
Enthalpy accuracy (%)	+/- 0.5*
Calorimetric precision (%)	+/- 0.8*
RMS noise (µW)	0.08
Resolution (µW)	0.0015; 0.015
Dynamic Range (mW)	+/- 12; +/- 120
GENERAL	
Cells volume (ml)	Up to 1 (standard cell)
Pressure measured and controlled (bar [psi])	400 [5,800]
Weight (kg)	38
Dimensions (Height/Width/Depth)	40/53/58 cm 15.7/20.9/22.8 inch
Power requirements	230V-50/60 Hz

\* Based on naphthalene melting tests

An external water circuit is also in contact with the outer walls of the thermostat to preserve its Peltier elements at extreme temperatures. This way, the microcalorimeter can operate at temperatures as low as -20 °C and as high as 170 °C.

The 3D sensor of MICROCALVET ULTRA is composed of **high sensitivity and high temperature Peltier elements**. They have one face in contact with the measurement cell and another in contact with a temperature control chamber.

MICROCALVET ULTRA's temperature control is based on a **heat transfer fluid circulation**: the fluid is continuously pumped into a thermostat where it is heated or cooled. The fluid then flows into the cavities of a temperature control chamber around the 3D sensor, which is brought to the set temperature.

This robust design enables the **fine-tuning of the heating and cooling rates** even down to 0.001°C/min and the **very good temperature stability** of MICROCALVET.

The sample, within a measurement cell, is placed directly into the center of the sensor's measurement zone. The cell can be a simply closed cylinder, or equipped with tools for mixing and stirring, gas or liquid flow, pressure control, and coupling to extra instrumentation.

Cells and tools are made of temperature and corrosion resistant metals and polymers.

New cells can be designed and configured to suit your application.

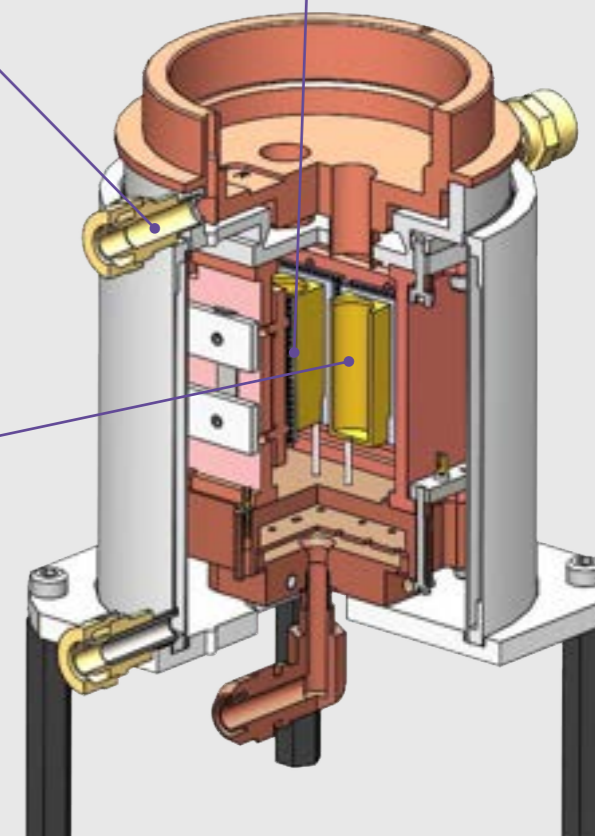

Cross section of the MICROCALVET ULTRA calorimeter

## MICROCALVET ULTRA 4C



### HIGHEST HEAT MEASUREMENT ACCURACY

Calvet 3D sensor based on Peltier elements with Joule effect calibration

### DUAL SAMPLE TESTING

4C means four cells, i.e. dual sample, for greater throughput and a preserved accuracy even with large heat effects

### MODIFIABLE TEMPERATURE CONDITIONS

for increased flexibility and replication of real life conditions between -20 and 170°C

### CONVENIENT INTERCHANGEABLE CRUCIBLES AND CELLS

to perform even the most demanding experiments using one instrument :

- high pressure (up to 400 bar) and high vacuum, pressure measurement and control
- mixing experiment

### EXTERNAL COUPLING CAPABILITY

designed to increase your research options including manometry, BET instrumentation, gas analyzers, humidity controllers and gas panels

TEMPERATURE	
Temperature range (°C)	-20 to 170
Temperature accuracy (°C)	+/- 0.07*
Temperature precision (°C)	+/- 0.15*
Programmable temperature scanning rate (°C/min)	0.001 to 1.2
HEAT & HEAT FLOW	
Enthalpy accuracy (%)	+/- 0.5*
Calorimetric precision (%)	+/- 1.5*
RMS noise (µW)	0.05
Resolution (µW)	0.0015; 0.015
Dynamic Range (mW)	+/- 12; +/- 120
GENERAL	
Cells volume (ml)	Up to 1 (standard cell)
Pressure measured and controlled (bar [psi])	400 [5,800]
Weight (kg)	38
Dimensions (Height/Width/Depth)	40/53/58 cm 15.7/20.9/22.8 inch
Power requirements	230V-50/60 Hz

\*Based on naphthalene melting tests

An external water circuit is also in contact with the outer walls of the thermostat to preserve its Peltier elements at extreme temperatures. This way, the microcalorimeter can operate at temperatures as low as -20 °C and as high as 170 °C.

The samples, within measurement cells, are placed directly into the center of the sensor's measurement zones. The cells can be simply closed cylinders, or equipped with tools for mixing and stirring, gas or liquid flow, pressure control, and coupling to extra instrumentation.

Cells and tools are made of temperature and corrosion resistant metals and polymers.

New cells can be designed and configured to suit your application.

The 3D sensor of MICROCALVET ULTRA 4C is composed of high sensitivity and high temperature Peltier elements placed around 4 cavities where 2 samples and 2 reference materials can be placed. The Peltier elements have one face in contact with the measurement cell and another in contact with a temperature control chamber.

MICROCALVET ULTRA 4C's temperature control is based on a **heat transfer fluid circulation**: the fluid is continuously pumped into a thermostat where it is heated or cooled. The fluid then flows into the cavities of a temperature control chamber around the 3D sensor, which is brought to the set temperature.

This robust design enables the **fine-tuning of the heating and cooling rates** even down to 0.001°C/min and the **very good temperature stability** of MICROCALVET.

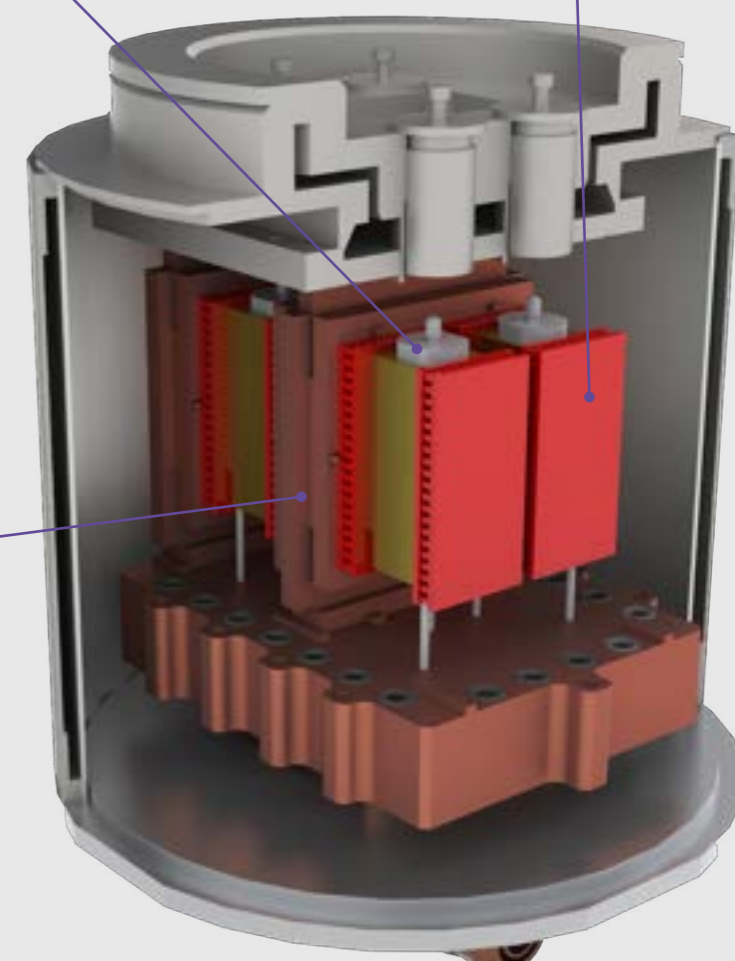

Cross section of the MICROCALVET ULTRA 4C calorimeter



Switzerland – France – China – United States – India – Hong Kong  
For contact details: [www.setaramsolutions.com](http://www.setaramsolutions.com) or [setaram@kep-technologies.com](mailto:setaram@kep-technologies.com)

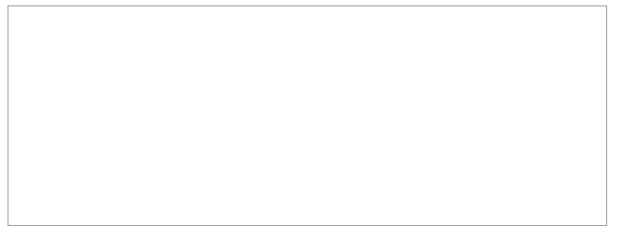

MC • Specifications are given as indications only and are not contractual • 07/20